

## Aurora Undercounter Refrigeration, Stainless Steel

ITEM: 59097 59099  
 MODEL: RE-CN-0011E-B-HC RE-CN-0015E-B-HC



48" wide  
59097



60" wide  
59099

### The perfect solution to add cold storage space for frozen products and ingredients conveniently within reach.

This undercounter refrigeration is perfect for cold food storage operations while saving space. Built with durable stainless steel for heavy-duty use, it features user-friendly controls and eco-friendly R290 refrigerant for reliable, energy-efficient performance.

#### FEATURES:

- Stainless steel interior and exterior
- Refrigeration system keeps food at safe
- Self-closing doors with 90-degree stay-open feature
- Adjustable heavy-duty PVC coated shelves
- Digital control system makes it easy to adjust temperature set point and defrost frequency
- Hydro-carbon R290 refrigerant, which is environmentally friendly and more efficient



**TECHNICAL SPECIFICATION**

| Features                  | 48" wide<br>with 11 cu.ft. (320 L) capacity       | 60" wide<br>with 15 cu. ft. (425 L) capacity     |
|---------------------------|---|--|
| Item                      | 59097   | 59099  |
| Model                     | RE-CN-0011E-B-HC                                  | RE-CN-0015E-B-HC                                 |
| Capacity                  | 11.3 cu.ft (320 L)                                | 15 cu. ft. (425 L)                               |
| Number of Doors           | 2 Swing Doors – Solid Doors                       |  |
| Self-closing Door         | Yes   |  |
| Number of Shelves         | 2   |  |
| Shelf Capacity (kg/pc)    | 88 lb (40 kg)                                     |  |
| Shelf Material            | Plastic coated                                    |  |
| Number of Casters         | 4   |  |
| Power                     | 270 W   | 285 W  |
| Amps                      | 2.4 A   | 2.6 A  |
| Electrical                | 115V / 60Hz / 1                                   |  |
| Type of Controller        | Digital   |  |
| Temperature Range         | 0.5 - 4.4°C (33 - 40°F)                           |  |
| Refrigerant               | R290  |  |
| Insulation Material       | Cyclopentane                                      |  |
| Cooling System            | Ventilated  |  |
| Defrosting                | Automatic   |  |
| Interior Dimensions (WDH) | 42.64" x 19.84" x 23.5"<br>(1083 x 504 x 597 mm)  | 55.6" x 19.84" x 23.5"<br>(1413 x 504 x 597 mm)  |
| Net Weight                | 214 lb (97 kg)                                    | 254 lb (115 kg)                                  |
| Net Dimensions (WDH)      | 47.24" x 29 1/2" x 38.8"<br>(1200 x 750 x 985 mm) | 60.2" x 29 1/2" x 38.8"<br>(1529 x 750 x 985 mm) |
| Plug Type                 | NEMA 5-15P  |  |

\* This equipment is intended for indoor environment using where ambient temperature do not exceed 26°C(80°F) & 55% relative humidity

## TECHNICAL DRAWING

48" wide  
59097

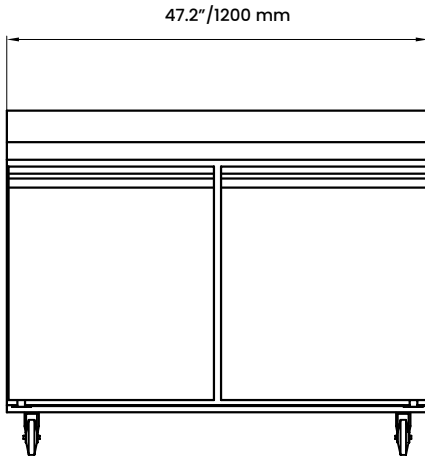

ELEVATION

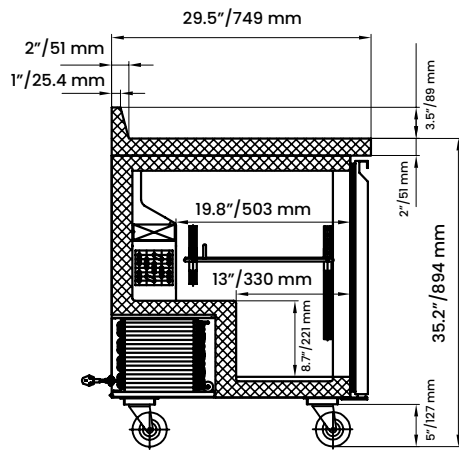

SECTION VIEW

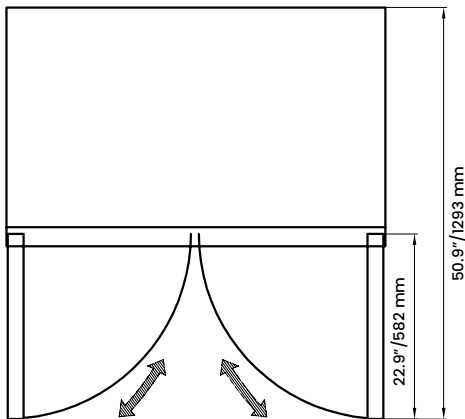

PLAN

60" wide  
59099

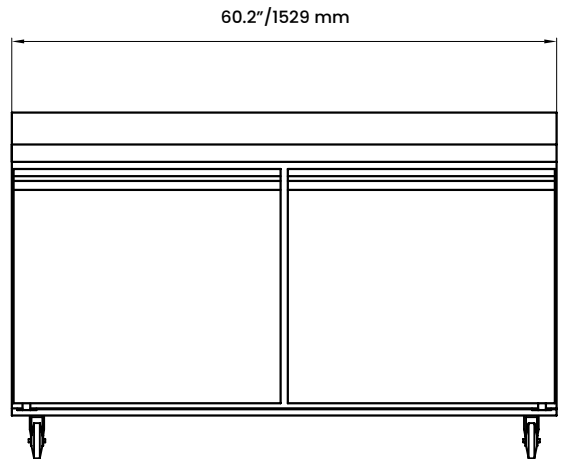

ELEVATION

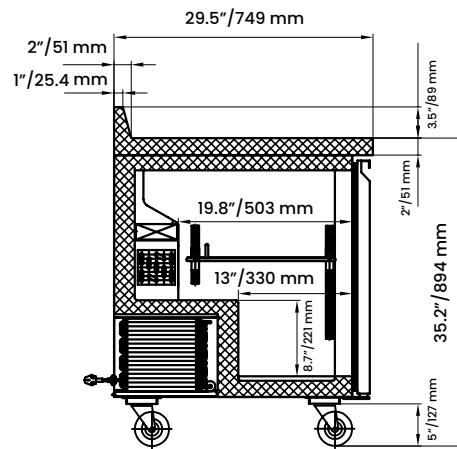

SECTION VIEW

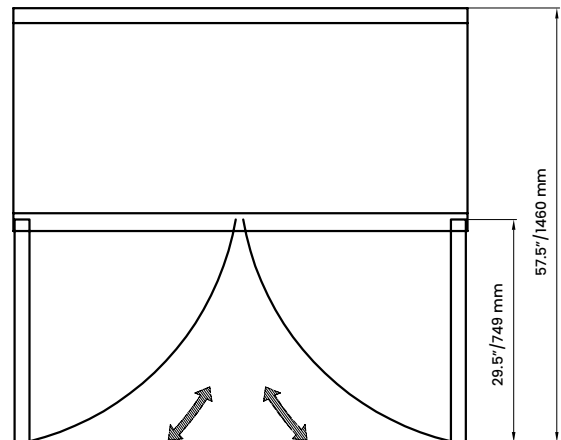

PLAN